

Légende/Legend

Direction of rotation	Sens de rotation
I) anticlockwise (normally opening)	I) sens antihoraire (cas général pour l'ouverture)
II) Clockwise (Normally closing)	II) sens horaire (cas général pour la fermeture)

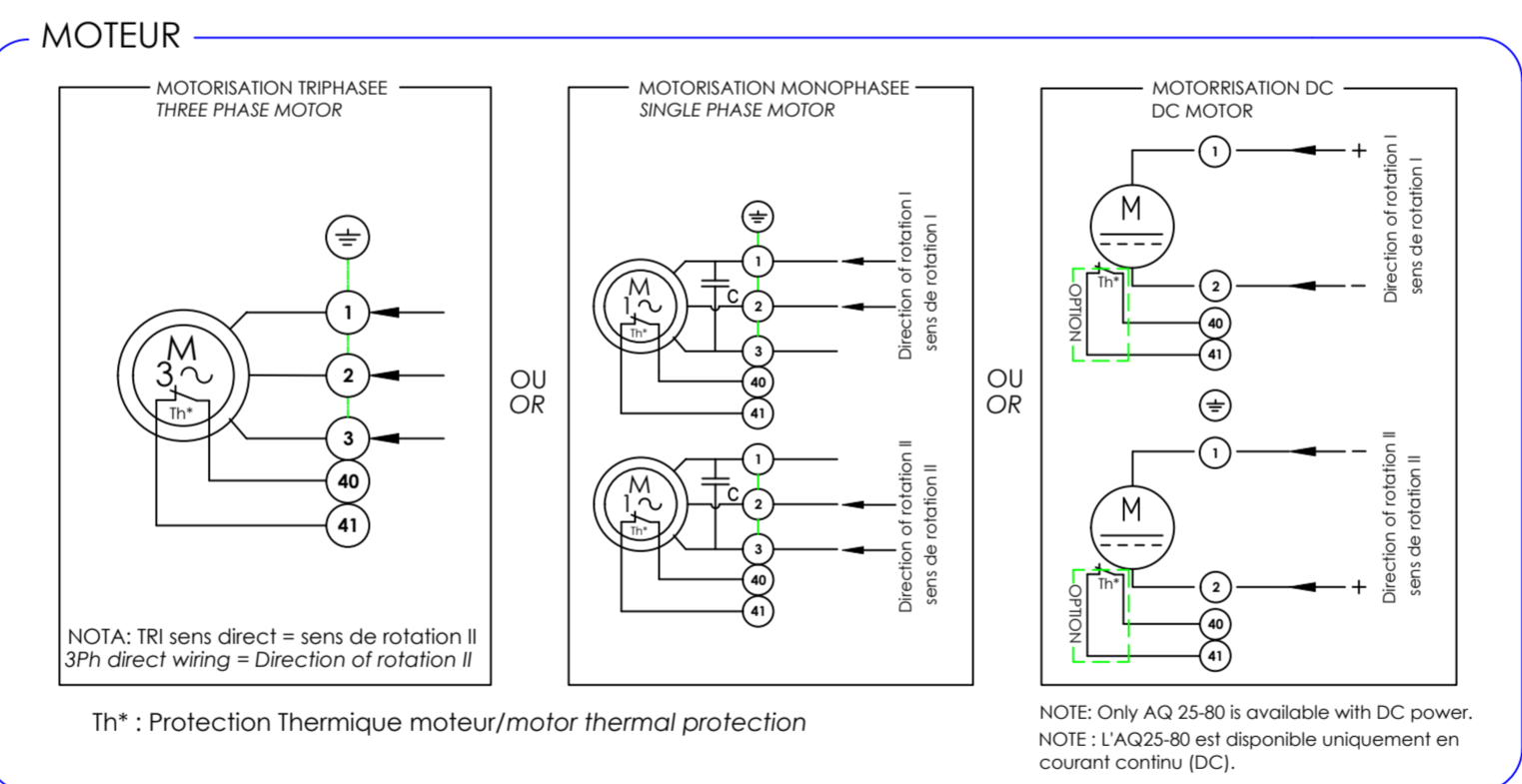

BERNARD CONTROLS

4 rue d'Arsonval BP 91
95505 GONESSE CEDEX
TEL. +33 (0)1 34 07 71 00
FAX. +33 (0)1 34 07 71 01
www.bernardcontrols.com

Ce plan étant notre propriété, il ne peut être reproduit ou communiqué sans notre autorisation écrite.
This drawing is our property and may not be reproduced or communicated without our written authorization.

**AT/AQ-25 to 100 1PH/3PH/CC SWITCH
1PH/3PH/DC AT/AQ-25 to 100 SWITCH**

4 Fins de Course, 2 Limiteur d'Effort, Potentiomètre, TAM
4 Travel Limit Switches, 2 Torque Limit Switches, Potentiometer, TAM

Projet/Project:		Etude/Study:		Modification: DM_25140	
Dessiné par: Designed by: NCA 06/08/25	Vérifié par: Checked by: C.ZHAO 11/08/25	Approuvé/Approved PROTO ->	Approuvé/Approved PROD RCO 28/02/26	WD_500569_FR_EN	Planche/Sheet: 1/1
				Ind./Rev.:	B