

**Légende / Legend**

Direction of rotation	Sens de rotation
I) anticlockwise (normally opening)	I) sens antihoraire (cas général pour l'ouverture)
II) Clockwise (Normally closing)	II) sens horaire (cas général pour la fermeture)

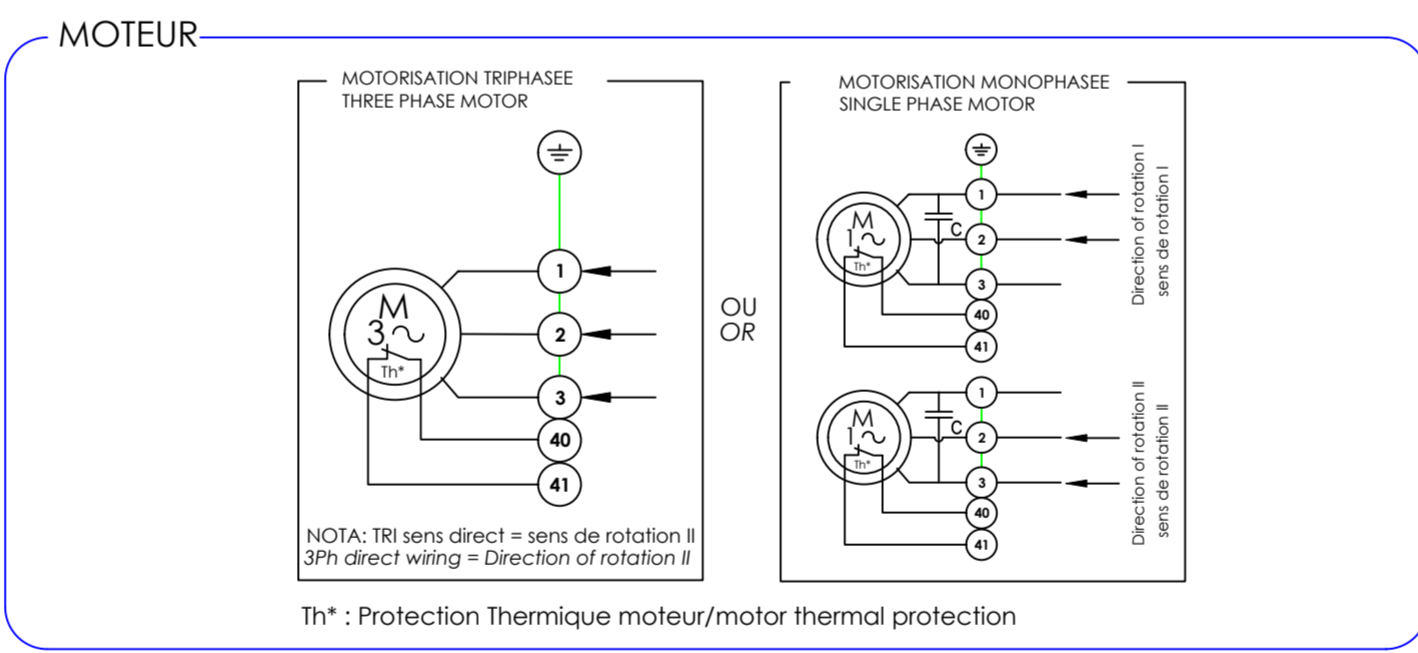

4 rue d'Arsonval BP 91  
95505 GONESSE CEDEX  
TEL. +33 (0)1 34 07 71 00  
FAX. +33 (0)1 34 07 71 01  
www.bernardcontrols.com

AT/AQ-25 à 250 1PH/3PH STANDARD  
1PH/3PH AT/AQ-25 to 250 STANDARD

Ce plan étant notre propriété, il ne peut être reproduit ou communiqué sans notre autorisation écrite.  
This drawing is our property and may not be reproduced or communicated without our written authorization.

4 Fins de Course, 2 Limiteur d'Effort, Chauffage  
4 Travel Limit Switches, 2 Torque Limit Switches, Heater

Projet/Project: 15M24		Etude/Study:		Modification: DM_26076	
Dessiné par: Designed by: NCA 03/04/26	Vérifié par: Checked by: C.ZHAO 03/04/26	Approuvé/Approved PROTO ->	Approuvé/Approved PROD RCottereau 08/05/26	WD_500062_FREN	Planche/Sheet: 1/1
				Ind./Rev.: D	